

See discussions, stats, and author profiles for this publication at: <http://www.researchgate.net/publication/228401518>

# Community Based Independent Power Plant: A Case for Renewable Energy Resources

ARTICLE · JANUARY 2008

---

READS

83

5 AUTHORS, INCLUDING:



Cajethan Nwosu

University of Nigeria

13 PUBLICATIONS 10 CITATIONS

SEE PROFILE



Cosmas Ogbuka

University of Nigeria

20 PUBLICATIONS 13 CITATIONS

SEE PROFILE

# Community-Based Independent Power Plant: A Case for Renewable Energy Resources.

C.A. Nwosu, M.Eng.<sup>1\*</sup>, G.C. Asomba, Ph.D.<sup>2</sup>, and C.U. Ogbuka, B.Eng.<sup>1</sup>

<sup>1</sup>Department of Electrical Engineering, University of Nigeria, Nsukka, Nigeria.

<sup>2</sup>Department of Physics and Astronomy, University of Nigeria, Nsukka, Nigeria.

\*E-mail: [cajethannwosu@yahoo.com](mailto:cajethannwosu@yahoo.com)  
[grg\\_chira@yahoo.com](mailto:grg_chira@yahoo.com)  
[ucogbuka@yahoo.com](mailto:ucogbuka@yahoo.com)

## ABSTRACT

Theoretical analysis of how wind power can be complemented by hydropower with pump storage to provide firm and all green power is presented. A battery sub-unit comprising battery banks and current source inverter provides the needed reactive power for the magnetization of the wind/hydro turbine generators and the load. A reactive power compensator is included to offset any reactive power imbalance between the sources and the sinks. A case study of wind and small hydropower capacity potentials in surveyed states in Nigeria was highlighted to accentuate the applicability of wind-small hydropower hybrid power plant in these locations.

(Keywords: wind power, hydroelectricity, hydro power, small scale, renewable energy, pump storage)

## INTRODUCTION

Several questions and arguments have been raised about the viability of renewable energy resources as an efficient substitute to fossil fuels. The usual arguments center mostly on the factors which include: capacity credit, ready availability, dispatchability, etc., of the renewable sources when compared to the conventional sources. The literature addressing the adverse effects of the conventional sources in our environment abound. Most of the renewable resources, especially wind potential, are stochastic and this may be a contributory factor to the slow renewable resources penetration of the energy system.

Consumer energy demand fluctuates on daily and seasonal bases, a factor which restricts the use of renewable energy sources for satisfying alone,

without energy backup, the ever increasing energy demands of the consumer.

There are periods when these stochastic sources are in abundance and when they are unavailable. Since electricity is very difficult or expensive to store in large quantities, it must be produced exactly at the it is consumed. Several schemes in electricity generation have been proposed in order to respond to instant fluctuations in electric power demand. Kaldellis, et al. [1], evaluated the wind-hydro energy solution for remote islands, which consisted of an interconnected wind farm, a small hydroelectric plant, a water pump station, and two groups of reservoirs. In this hybrid system, the surplus energy is stored by the water pumping system.

Bakos [2], analyzed the operation of a wind farm combined with a reversible-hydro power station and a parallel water pump station. When an energy surplus is produced during the operation of the system, it is diverted to the water pump station that carries water from lower tanks to a higher level and stores it in the form of hydrodynamic energy. In another study where wind energy is added to hydropower [3], the wind power is interconnected to the grid and the hydropower is used to compensate for the wind power fluctuations in the context of a global energy balance. In reference [3], hydropower provides the backup capacity. In reference [2], autonomous power stations (APS), which consisted of diesel engines, provided the needed backups.

The use of APS as backups stems from the anticipation that even though wind and water power, two variable resources, have the potential to complement each other there may be a season of lack of energy from the hybrid system.

The use of internal combustion engines is also dictated when the energy demand becomes too high to be covered sufficiently by both wind and hydro systems. The unique possibility in combination of renewable resources in conjunction with backups to provide not just firm but green power has been the underlying motivation in this area of research.

The power output from the wind farm is complemented with hydropower to guarantee firm power. Figure (1a) shows a month during which the wind energy resource is low. Figure (1b) shows a month with high availability of wind energy. It is clear in both cases that the wind power is subject to short-term fluctuations (depicted in dark gray) and hydropower is used to compensate (depicted in light gray) for these variations. This indicates that the hydropower plant must be able to increase or decrease production very quickly in order to obtain firm power.

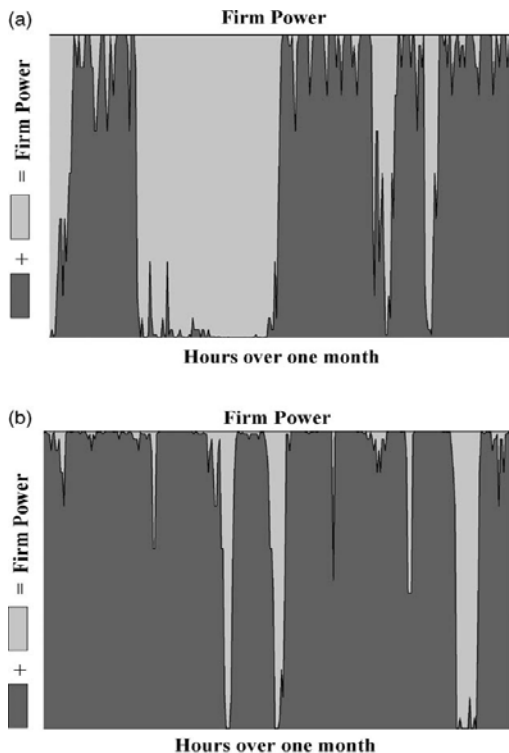

**Figure 1:** The Firm Power is the Sum of Hydropower ( $P_h$ ) and Wind Power ( $P_w$ ).  
 (a) A Month that Presents a Low Wind Resource.  
 (b) A Month that Presents a High Wind Resource.

Two different sources of energy, wind and hydro, may exhibit different levels of energy conversions and as such, may impact differently on the dynamics of the hybrid system, especially in the case where one or both draw reactive power. In wind turbines, squirrel-cage and wound rotor induction machines, both of which require reactive power for proper operation, are usually favored. This reactive power, therefore, has to be provided by an APS or synchronous machine will be used in the hydro-turbine. This arrangement, yet, does not solve the problem since it is anticipated that there may be a time of lack of hydropower, in which case the wind turbine is rendered impotent even at the period of enough wind.

In this paper, a wind-hydro hybrid system, which consists of an interconnected wind farm, a small hydroelectric plant, a water pump station, and battery banks to maintain firm power are proposed. The battery banks are made up of two sub-units, B1 and B2. Sub-unit B1 consisting of bank of battery and a voltage source inverter act as backup while sub-unit B2 consisting of bank of battery and a current source inverter act as reactive current injector. The latter provides the voltage and frequency of operation of the hybrid plant.

By direct control of the reactive current through adjustment of firing angle or modulation index, the current source inverter controls the injection of reactive power to the hybrid system. To this end, sub-unit B2 remains constantly connected to the system. Asynchronous machines are assumed in both the wind- and hydro turbines. The block diagram which also shows the energy flow of the hybrid system is shown in Figure 2.

## HYBRID POWER GENERATION

Detailed models of hydro, and wind systems are in the literature. Thus, only the final expressions for the power outputs of these components are given below.

### Wind Power

The wind power output supplied to the bus is given by:

$$P_w = \eta_t \cdot \eta_g \cdot 0.5 \cdot \rho \cdot \pi \cdot C_p(\lambda) \cdot R^2 \cdot V^3 \quad (1)$$

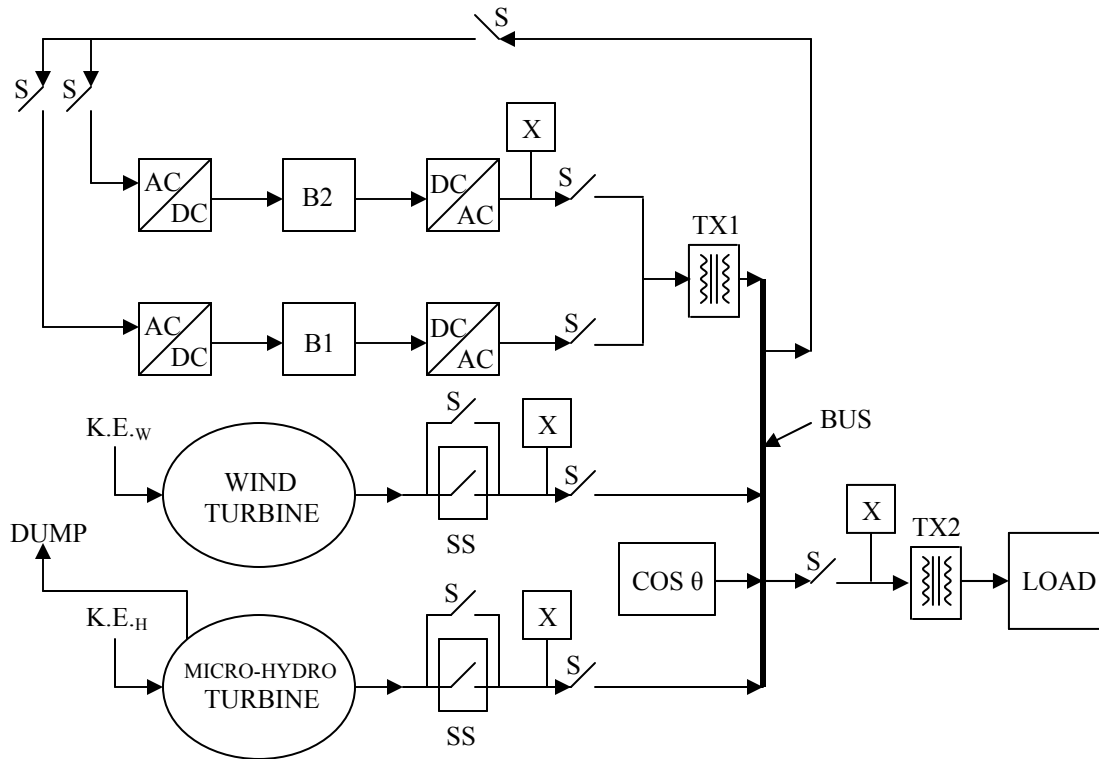

- AC/DC = Rectifier  
 DC/AC = Inverter  
 B1, B2 = Battery banks  
 COS θ = Reactive power compensator  
 X = Device that measures real power, reactive power, and voltage  
 K.E.w = Kinetic energy in the wind  
 K.E.H = Kinetic energy due to water at a given height  
 TX = Transformer  
 SS = Soft starter  
 S = Switch

**Figure 2.** Block diagram of the proposed wind-microhydro hybrid power plant.

where  $V$  is the wind speed in m/s,  $\rho$  is air density ( $\text{kg}\cdot\text{m}^{-3}$ ),  $R$  is the blade radius in m,  $C_p(\lambda)$  is the coefficient of power which depends on the particulars of the turbine blade, design and can be represented as a function in  $\lambda$ ,  $\eta_t$  and  $\eta_g$  are the wind turbine and generator efficiency, respectively.

### Micro-Hydro Power

The electrical power generated by the micro-hydro unit is given by:

$$P_h = \eta_{\text{hyd}} \cdot \rho_{\text{water}} \cdot g \cdot H_{\text{net}} \cdot Q \quad (2)$$

where  $\eta_{\text{hyd}}$  is the hydro efficiency as obtained from the quadratic fit to the manufacturers' data,  $\rho_{\text{water}}$  is the density of water,  $g$  is the acceleration due to gravity,  $H_{\text{net}}$  is the effective head, and  $Q$  is the flow rate.

### Battery Power

The state of charge of battery can be calculated from the following equations:

Battery discharging,

$$P_b(t) = P_b(t-1) \cdot (1 - \sigma) - \left( \frac{P_h(t)}{\eta_i} - P_l(t) \right) \quad (3)$$

Battery charging,

$$P_b(t) = P_b(t-1) \cdot (1 - \sigma) + \frac{(P_h(t) - P_l(t))}{\eta_i} \cdot \eta_b \quad (4)$$

where  $P_b(t-1)$  and  $P_b(t)$  are the battery energy at the beginning and the end of interval  $t$ , respectively,  $P_l(t)$  is the load demand at the time  $t$ ,  $P_h(t)$  is the total energy generated by micro-hydro unit and wind generators at the time  $t$ ,  $\sigma$  is the self-discharge factor and  $\eta_b$  and  $\eta_i$  are the battery and inverter efficiency, respectively, as obtained from the manufacturers' data.

The total hybrid power generated at any time  $t$  is given by:

$$P(t) = \sum_{h=1}^{N_h} P_h + \sum_{w=1}^{N_w} P_w \quad (5)$$

## HYBRID POWER OPTIMIZATION

Optimal dispatch strategy of hybrid energy system is to find the most economical schedule for different combinations of renewable generators with battery backup, satisfying load balance, resource availability and equipment constraints [4]. The dispatch strategy here is that energy is stored in water pump station that carries water from lower tanks to a higher level and stores it in the form of hydrodynamic energy, if the renewable energy is in excess after meeting the demand and is utilized, if load exceeds the renewable energy. Battery sub-unit B1 is used as part of the system to respond to the emergency cases where renewable generation and stored energy are not sufficient to meet the load. To this end, B1 should be intermittently monitored and charged to meet emergency demand.

The rated power of the hybrid plant is determined by the nominal power of sub-unit B1 since as a backup the unit is expected to supply and maintain firm power in the event of lack of power from the hybrid components. This is dependent, however, on the state of charge (SOC) of battery B1. This condition, however, is anticipated to be rare with a reversible-hydro power station and a parallel water pump station. By this arrangement, the hydropower plant must be able to decrease or increase production very quickly in order to obtain firm power.

## Conceptual framework for the energy balance

The conceptual framework of the energy balance of the system is based on performance of the capacity factor for both wind power and hydro power units. Capacity factor is defined as the fraction or percentage of total energy delivered  $E_D$  from a facility over a period of time, divided by the maximum energy  $E_N$  that could have been delivered if the facility was used at its maximum capacity over the entire period, given by [5]:

$$CF = \frac{E_D}{E_N} = \frac{\int_{t=0}^T P(t) dt}{\int_{t=0}^T N dt} = \frac{\int_{t=0}^T P(t) dt}{NT} \quad (6)$$

where  $t$  is the time,  $T$  is a period of time,  $P$  (that depends on time) is the power generation and  $N$  is the nominal capacity of the facility and is a constant.

On the other hand, the plant power from the hybrid system can be expressed as the sum of wind power  $P_w$  and hydro power  $P_h$ :

$$P_p = P_w + P_h \quad (7)$$

taking into account that  $P_p$  does not depend on time (since it is a plant power) and considering a period of time  $T$ , the energy delivered by the hybrid system can be estimated through:

$$P_p T = \int_{t=0}^T P_w(t) dt + \int_{t=0}^T P_h(t) dt \quad (8)$$

and using Equation (6) we can write:

$$P_p = CF_w N_w + CF_h N_h \quad (9)$$

which gives wind power output as:

$$P_w = CF_w N_w \quad (10)$$

and hydro power output as:

$$P_h = CF_h N_h \quad (11)$$

where  $CF_w$  and  $CF_h$  are the capacity factors for the wind power and hydro power units.  $N_w$  and  $N_h$  are the rated powers for the wind power and hydro power units, respectively.

When there is little or no wind, the hydro unit must supply 100% of total power to guarantee

plant power output. Therefore the capacity factor for the hydro unit  $CF_h = 1$ . On the other hand, when the wind unit is operating at rated power,  $CF_w = 1$ , the plant power should be equal to the rated power for the wind unit  $N_w$ . In standard systems, it is important that the rated power for the wind unit  $N_w$  and the rated power for the hydro unit  $N_h$  must be the same to guarantee plant power  $P_p$ :

$$P_p = N_w = N_h = N \quad (12)$$

In summary, when the wind unit is operating at full capacity there is no need to generate hydro power. Therefore the hydro power capacity factor is  $CF_h = 0$ . In periods of low wind, the hydro power capacity factor is  $CF_h = 1$  and the wind plant capacity factor is  $CF_w = 0$ . In fact, the range for the capacity factors is  $0 \leq CF \leq 1$ . Therefore:

$$CF_w + CF_h = 1 \quad (13)$$

The rated power for the hybrid wind-hydro system  $N_{wh}$  is established by the sum of the rated power of wind  $N_w$  and the rated power of the hydro  $N_h$ :

$$N_{wh} = N_w + N_h = 2N \quad (14)$$

therefore the capacity factor of the hybrid wind-hydro system is  $CF_{wh} = 1/2$ , this is:

$$PP = 0.5 (N_{wh}) = N \quad (15)$$

according to Equation (12).

### **Reactive power balance**

The current controlled battery inverter acts as a local grid for the hybrid power plant. The system also has a reactive power compensator to provide the required reactive power in addition to the reactive power generated by the battery inverter. Small changes in reactive power are mainly dependent on the voltage set by the battery inverter. The reactive power balance equation of the system under steady state condition is:

$$Q_{BI} + Q_{RC} = Q_L + Q_{WG} + Q_{HG} \quad (16)$$

where,

$Q_{BI}$  = reactive power generated by battery inverter,

$Q_{RC}$  = reactive power generated by compensator,

$Q_L$  = reactive power load demand,

$Q_{WG}$  = reactive power required by the wind generator,

$Q_{HG}$  = reactive power required by the hydro generator.

For the incremental reactive power balance analysis of the hybrid system, let the hybrid system experience a reactive power load change of magnitude  $\Delta Q_L$ . Due to the action of the current controlled inverter and compensator, the system reactive power generation increases by an amount  $\Delta Q_{BI} + \Delta Q_{RC}$ . The net reactive power surplus in the system, therefore, equals  $\Delta Q_{BI} + \Delta Q_{RC}$

$$\Delta Q_L - \Delta Q_{WG} - \Delta Q_{HG} = 0 \quad (17)$$

Equation (17) is true owing to the action of the current controlled inverter. At any instant of time, there is a zero net exchange between the energy sources and the energy sinks both real and reactive power). The voltage and frequency of the system will change to maintain equilibrium.

### **POWER QUALITY**

An automated wind-hydro hybrid power system is called upon to a wide variety of tasks which include such things as (1) automatic dispatch of the sub-unit B1 to ensure proper loading and good operating efficiency, (2) operator notification of any warning or alarm conditions, (3) performance data logging to facilitate troubleshooting and maintenance, and (4) management of the secondary loads to ensure that excess power is directed where it is most needed. Fundamentally, however, the most critical tasks of the system are to provide good frequency and voltage regulation. Unless the system can provide good power quality, as measured primarily by frequency and voltage stability, it is not viable.

### **Frequency Regulation**

The entire power system, including all its generators, distribution wiring, and even motors present in the village load, can be thought of as one big electromechanical entity. Power flows into this system as power from the wind transferred to the wind turbine rotor, kinetic energy of falling water transferred to the hydro turbine rotor, and electric power drawn from the battery. Power flows out of the system to

consumer resistive loads, to consumer mechanical loads, to secondary loads, and as various mechanical and electrical losses. At any given moment, if more power is flowing into the system than out of it, the difference will be stored as an increase in kinetic energy of the water in the form of hydrodynamic energy, and/ or chemical energy of the battery of sub-unit B1. The effect of any power imbalance in the system is expressed in Equation (18):

$$\sum P_{\text{SOURCES}} - \sum P_{\text{SINKS}} = \frac{d(\text{K.E}_{\text{W.}})}{dt} + \frac{d(\text{C.E}_{\text{B.}})}{dt} \quad (18)$$

where:

P = active power (kW)

K.E<sub>W.</sub> = kinetic energy of water in the reservoir

C.E<sub>B.</sub> = chemical energy of the battery

The task of frequency regulation is essentially a problem of maintaining an instantaneous balance of the real power flowing into and out of the system. Any power imbalance typically shows up as an increase or decrease in voltage on the AC and/or DC side of the inverter.

### Voltage Regulation

Analogously, regulating the AC voltage of the power system is a problem of maintaining equilibrium between the source and sinks of reactive power (VARs) in the system. The induction generators of the wind and hydro turbines, transformers in the distribution system, and induction motors in the consumer load are all reactive power sinks. The current controlled battery inverter which acts as a local grid and reactive power compensator are sources of reactive power. Generally they are supplying the reactive power demanded by the sinks. Unlike the case of real power, where an imbalance can be absorbed by the system as a change in stored kinetic energy and chemical energy, there is no storage mechanism for "reactive energy", which only actually exists as a mathematical construct [6].

The reactive power supplied by the sources is inherently equal to the reactive power absorbed by the sinks. This is expressed in Equation 19, in which the reactive power flows for each component are expressed as functions of voltage:

$$\sum Q_{\text{SOURCES}}(V_{\text{AC}}) - \sum Q_{\text{SINKS}}(V_{\text{AC}}) = 0 \quad (19)$$

where:

Q = reactive power (KVAR)

V<sub>AC</sub> = AC bus voltage

If the reactive power sources are unable to deliver the reactive power demanded by the sinks, the bus voltage will fall such that the equilibrium is maintained. With reactive power, the issue is not so much ensuring that equilibrium is maintained (which is automatic), but that the equilibrium occurs at the desired voltage level.

### **PERFORMANCE REQUIREMENTS OF THE CONTROL SYSTEM**

Perhaps the most critical operation of the hybrid system is the ability to coordinate different actions in the component units in order to maintain steady plant power. To facilitate the coordination and control of these units, digital measuring devices marked "X" are installed at the required positions of the hybrid, plant Figure 2.

The monitoring is essential and enables the decision on which unit(s) should be switched into or out of the local grid especially during variations in the stochastic sources [7]. Information from the load and the component units which may primarily be in analogue forms are converted to digital forms before routing them to a control center which in turn initiates an appropriate action. In an automated system, a control center may be a personal computer or in most cases a dedicated programmable logic controller (PLC) otherwise known as industrial computer. The use of PLC to interpret the states of input signals and provide desired outputs according to the way it is programmed is proposed in this paper. Information to the PLC master is routed through Profibus slaves. Before reaching the Profibus slaves, analogue information like wind speed and states of charge of batteries are electronically converted to digital signals. States of active power P, reactive power Q, and voltage V, of all the units, reactive power compensator, and input to the load transformer are also linked to the PLC through Profibus. Constant monitoring of these states provides data with which PLC takes decision based on a program in it.

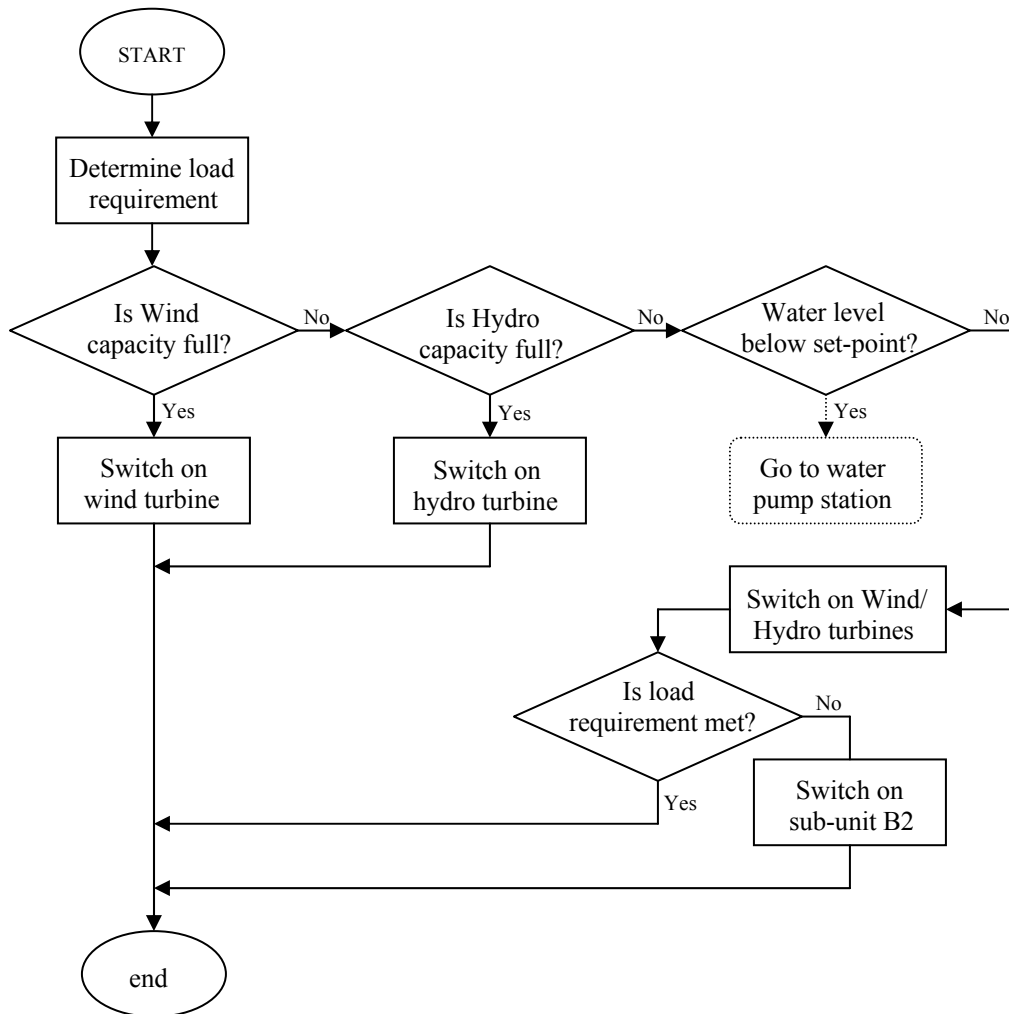

**Figure 3:** Power Flow Algorithm of the Wind-Hydro System.

The control loop shown in Figure 3 will be executed approximately once every 20 milliseconds (ms). The reactive power requirement, for instance, of the wind turbine induction generator and/or hydro turbine induction generator, will be compared to the maximum reactive power supply allowed for the sub-unit B2 in order to determine whether to switch into the grid the reactive power compensator or not.

In order to reduce the inrush current, as the induction generators of the hybrid plant are connected, soft-starters fitted with by-pass switches, are used to magnetize the machines. In the most conventional way, a soft-starter is fitted before an induction generator. In this scheme, the soft-starters are placed after the induction

generators to limit the amount of energy drawn from the local grid. The currents flowing through the generators are limited by sending delayed ignition pulses to the anti-parallel thyristors. The induction generators are allowed to attain their nominal speed before the main contactors are closed to bypass the soft-starter.

### CASE STUDY

A good number of potential sites exist in Nigeria where the hybrid scheme proposed in this paper is suitable. Globally, Nigeria is located within low to moderate wind energy zone. Figure 4 displays some data from extensive nationwide study on wind energy availability and potential in Nigeria



[8]. The study uses data on wind speeds and directions for 22 meteorological stations in Nigeria. The data is based on the 3-hourly records of wind for periods ranging from 12 to 33 years (1951 – 1983). It also shows the estimated maximum energy obtainable from a 10m and 25m diameter wind turbines with an efficiency of 30% at 25m height. The longer bars indicate the estimated maximum energy obtainable from a 10m diameter wind turbine, while the shorter bars represent the estimated maximum energy obtainable from a 25 m wind turbine.

Wind Energy Density Estimates at 25m Height in kWh/yr.

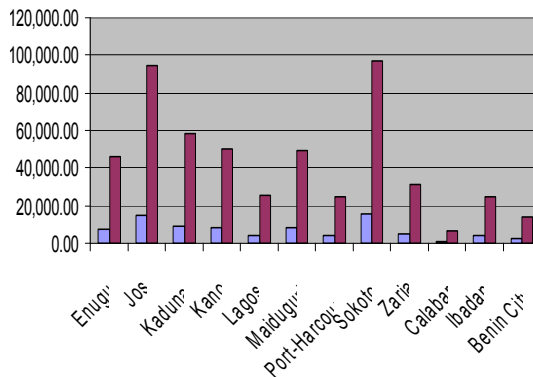

Figure 4: Wind Energy Availability and Potentials in Nigeria.

In Nigeria, several scores of small rivers and streams exist within the present split of the country into eleven River Basin Authorities, some of which maintain minimum discharge all the year round. Presently, the identified small scale hydro potential for Nigeria is 732 MW, out of which only 19 MW or about 2.60% has been developed. Figure 5 shows the potential capacity in MW of small hydro in surveyed sates in Nigeria. Further, there are pockets of capacity and study results available all over Nigeria, which can easily be harnessed for studies and development initiatives on small-scale hydro energy.

## CONCLUSIONS

The analysis presented in this paper validates the possibility of guaranteeing continuous availability feature of firm power by means of the hydropower with pump station used to compensate for wind fluctuations. A power flow algorithm has been

developed for optimized operation of the hybrid power plant.

Small Hydro Potentials in Surveyed States in Nigeria

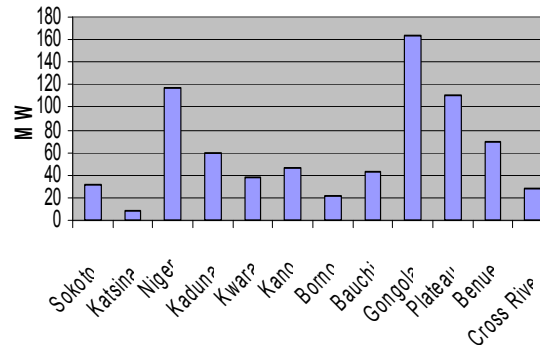

Figure 5: Potential Capacities in MW of Small Hydro in Surveyed Sates in Nigeria.

A good number of potential sites in surveyed states in Nigeria where the hybrid independent plant can be built have been highlighted. It is pertinent to point out that these surveyed sites by no means represent the overall potential sites which nature had blessed Nigeria with. It is hoped that with the recent deregulation in the power and energy sector coupled with the present global interest in renewable energy (sustainable energy) resources, the government, cooperate bodies, and cooperative societies will avail themselves of this opportunity to generate “all-green” power and save our environment from the global warming caused by greenhouse gases.

## REFERENCES

1. Kaldellis, J.K., K. Kavadias, and E. Christinakis. 2000. “Evaluation of the Wind-Hydro Energy Solution for Remote Island”. *Energy Converters Manager*. 42:1005 – 1120.
2. Bakos, G.C. 2002. “Feasibility Study of a Hybrid Wind/Hydro Power System for Low-Cost Electricity Production”. *Applied Energy* 72:599 – 608.
3. Belanger, C. and L. Gagnon. 2002. “Adding Wind Energy to Hydropower”. *Energy Policy*. 30:1279 – 1284.

4. Ashok, S. 2007. "Optimized Model for Community-Based Hybrid Energy System". *Renewable Energy*. 32(7):1155 – 1164.
5. Jaramillo, O.A., M.A. Borja, and J.M. Huacuz. 2004. "Using Hydropower to Complement Wind Energy: A Hybrid System to Provide Firm Power". *Renewable Energy*. 29:1887 – 1909.
6. Drouilhet, S.M. 1999. "Power Flow Management in a High Penetration Wind-Diesel Hybrid System with Short-Term Energy Storage". *Wind Power '99*. June 20 – 23:1 – 10.
7. Nwosu, C.M. 2007. "DenLab Energy System". Unpublished Research Study in TU-Delft: The Netherlands. 1 – 34.
8. Ikuponisi, F.S. 2003. "Status of Renewable Energy in Nigeria". Energetic Solutions: An International Conference On Making Renewable Energy a Reality. Nov. 21 – 27, 2003.

## SUGGESTED CITATION

Nwosu, C.A., G.C. Asomba, and C.U. Ogbuka. 2008. "Community-Based Independent Power Plant: A Case for Renewable Energy Resources". *Pacific Journal of Science and Technology*. 9(2):452-460.



## ABOUT THE AUTHORS

**Cajethan A. Nwosu** obtained his B.Eng. and M.Eng. degrees in Electrical Engineering from University of Nigeria, Nsukka, Nigeria, in 1994 and 2004 respectively. He is presently working toward his Ph.D. degree in Electrical Engineering. He is currently a lecturer in the Department of Electrical Engineering, University of Nigeria, Nsukka, Nigeria. His research interests include power electronic converters and renewable energy technologies.

**George C. Asomba, Ph.D.** is in the Department of Physics and Astronomy, University of Nigeria, Nsukka, Nigeria. His research interests are in condensed matter and materials science (magnetism, superconductivity, nanoscience and nanotechnology) and solar energy (photovoltaic and renewable energy). Asomba is married with children.

**Cosmos U. Ogbuka** obtained his B.Eng. degree in Electrical Engineering from University of Nigeria, Nsukka, Nigeria, with first class honors in 2003. He is presently pursuing his M.Eng. degree in Electrical Engineering. His research interests include machine drives and power electronics.